

Auto Fuel Injector Tester & Cleaner

Operation Instruction

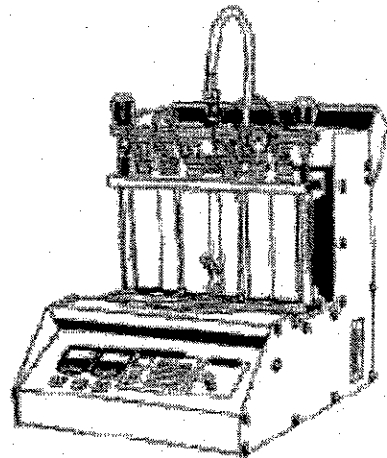
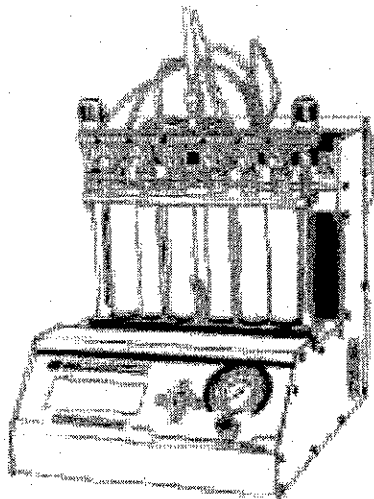
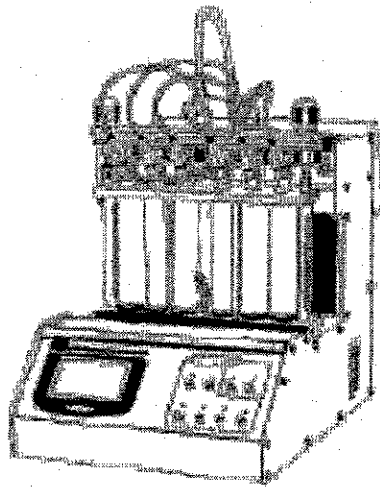

Warnings

Please read the following clauses carefully

1. No naked fire and smoking around the unit.
2. Only the cleaning and checking agent offered by our company can be used on the unit.

If other medical agent were introduced, it may cause damages to the coat, tube system or some rubble products.

3. **Using other medical agents will make warranty fail!**
4. Using cleaning agent as testing agent is forbidden. For it may cause the oil pump destroyed or stopped working.
5. The anti-creep age facility must be fixed on the power inlet. **A quality grounding line is necessary for the 220V entry.** So please making sure the Incidental power line is used.

Table of Contents

Model Size and Technology Parameters	1
Model Size	1
Functions and purpose	1
Working Conditions	2
Main Technology Parameters	2
Function Instruction	3
Operation Panel Sketch Map	3
Testing Items and Instruction	4
Preparation and Checking Criteria	10
Preparation	10
Fix Injector to Unit	11
Checking Criteria	14
Operation Guidelines	15
Ultrasonic Cleaning	15
Reverse Ultrasonic Cleaning	15
Reverse Flushing	15
Discharge Proportionality & Leak Hunting Test	16
Setting for Injecting Times	16
Tidy and Maintenance	17
Tidy	17
Maintenance	17
Notice	18
The Cleaning and Testing Agents	18
Incidental Accessories	19

General Introduction

1. Features and Function

1.1 Both the checking and cleaning operation are controlled by micro computer including dealing with dribbling, blocking, pulverization and the injector's angle. The unit can also control the quantity and proportion of fuel spray when injectors are in different running speed.

1.2 The operation items are shown by digital tube with high definition making the operation easy and convenient.

1.3 The powerful ultrasonic cleaning trough (70w) can clean several injectors at the same time. The filter pot of the injector can also be cleaned by ultrasonic wave.

1.4 You can adjust the time, frequency, injecting times, the minimum switch cycle freely in allowable range.

1.5 The patent compound bonder and general bonder base are applicable to US, Japan and Europe vehicles' Side-filled injectors.

1.6 The liquid level of the test tube (cylinder) can be shown directly, and the testing liquid can be used circularly.

1.7 The operating pressure can be regulated.

2. Working Conditions

2.1 Power Supply: AC110

2.2 Frequency: 50/60HZ

2.3 Power :< 120W

2.4 Environment Temperature :+10°C ~+30°C

2.5 Relative Humidity :< 85%

2.6 Magnetic Field Strength :< 400A /m

2.7 Intermittent Working

2.8 Avoid naked fire and combustible gas.

3. Main Technology Parameters

3.1 RPM: 0~7500r/min.

3.2 Injecting times: 0~9900times step length: 100

3.3 Pulse duration: 0~20.0ms step length: 0.1ms

3.4 Timing: 0~10min adjustable

3.5 System pressure: 0~0.5Mpa (adjustable)

3.6 Fuel tank capacity: 2000ml

3.7 Ultrasonic power: 70W (intermittent working)

3.8 Ultrasonic Frequency: 28KHZ 0.5KHZ

3.9 Cylinder capacity: 140ml

3.10 Cylinder measure accuracy: 0.2ml

3.11 Weight: 30Kg

Operation Instruction

Operation Panel:

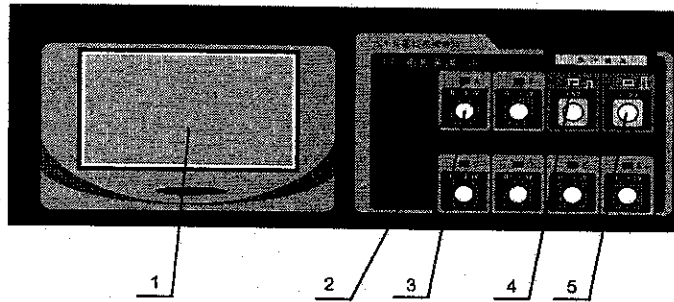

The main menu will be displayed in LCD while switch on the machine!
Touch the optional to enter the functions.

1. Touch screen.

2. Indicator light of 6 lines simulating signals.

3. Output of simulating signals

The 6 simulating signals are as following:

- A. simulating signal for Hall sensor
- B. simulating signal for pressure sensor
- C. simulating signal for liquid level sensor
- D. simulating signal for temperature sensor
- E. simulating signal for oxygen content
- F. simulating signal for flux sensor

4. Indicator light of pulse-simulating signal.

5. Output of pulse simulating signals (5V and 12 V).

Operation Keys explanation



Work key: for executing working items



Pause key: for pause the current working items



Stop key: for stop the current working items

BACK Back key: press it to back to main menu



Up arrow: for increasing



Down arrow: for decreasing

For different models with different panels, please subject to entity!

Testing Items and Instruction

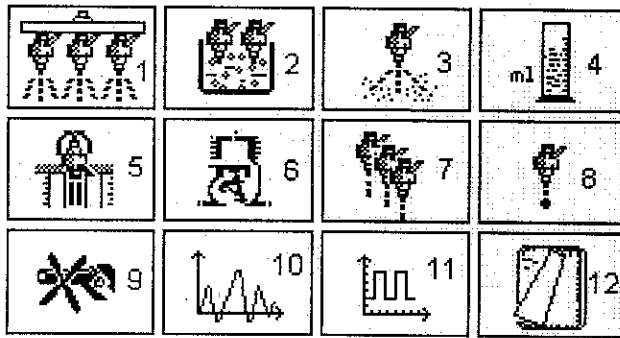

Main Operation Face Items

- | | |
|------------------------|-------------------------|
| 1 automatic test | 2 ultrasonic clean |
| 3 injector test | 4 oil spray amount test |
| 5 reverse flush | 6 accelerate speed test |
| 7 single cyc test | 8 leak check test |
| 9 no-disassembly clean | 10 simulate test |
| 11 pulse test | 12 unit info |

1 Automatical Test

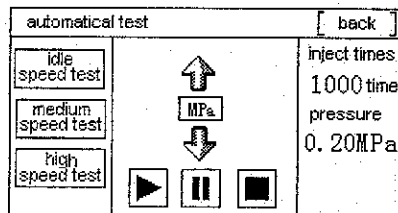

Touch “**Automatical**” item to enter the **Automatical** test function. Touch “work key” to run. The machine will run following tests(idle speed test/medium speed test/high speed test/accelerate speed test/shift speed test/leak check test) one by one. During running, you can adjust working pressure by touching up and down arrow.

“pause key” to pause the function and “stop key” to quit. “back key “ to back to the main menu.

2 Ultrasonic Cleaning Clean the injector needle valve.

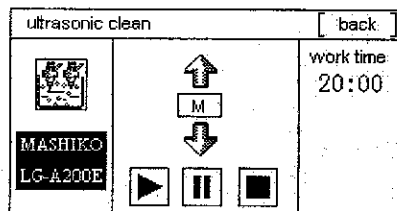

Touching the “**ultrasonic clean**” item on LCD to enter ultrasonic cleaning function, touching up and down arrow keys to adjust work time. Touch “**work key**” to run the function, “**pause key**” to pause the function. “**stop key**” to quit. “**back key**” to back to the main menu.

3 Injector Test

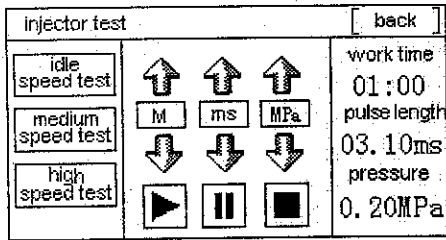

Touch “injector test” item on LCD to enter injector test function. Select relative idling/medium/high speed test items then adjust work time by touching up and down arrows. Touch “work key “to run the function. During running, you can press pulse/pressure up and down arrow to adjust injector’s pulse width and pressure.

“pause key” to pause the function and “stop key” to quit. “back key “ to back to the main menu.

4 Fuel Spray volume Test

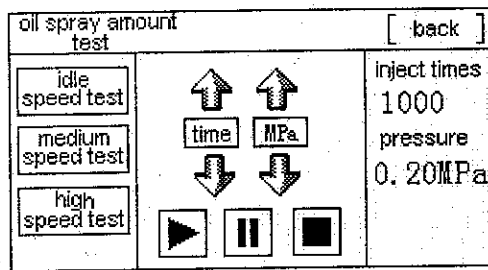

Touch “fuel spray amount” item to enter the function. Select relative idling/medium/high speed test items; adjust time by touching up and down arrow. Touch “work key “to run the function. During running, you can press up and down arrow to adjust injector’s pressure.

“pause key” to pause the function and “stop key” to quit. “back key “ to back to the main menu.

5 Reverse flush (default time: 1 min)

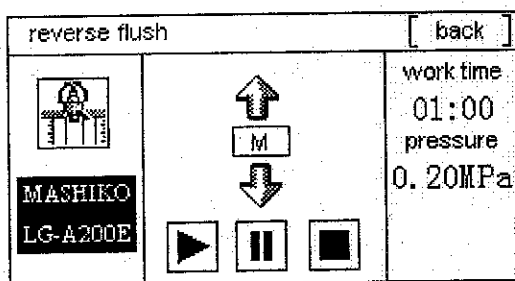

Touch “reverse flush” item to enter the function. Touch “work key” to run the function. During running, you can adjust working pressure by touching up and down arrow.

“pause key” to pause the function and “stop key” to quit. “back key “ to back to the main menu.

6 Accelerating Test

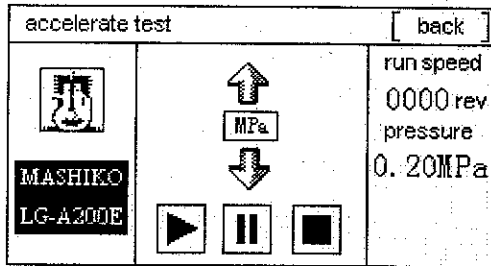

Touch “accelerate test” item to enter accelerate test and clean function. Touch “work key” to run the function. During running, you can adjust working pressure by touching up and down arrow.

“pause key” to pause the function and “stop key” to quit. “back key” to back to the main menu.

7 Single Cyc Test

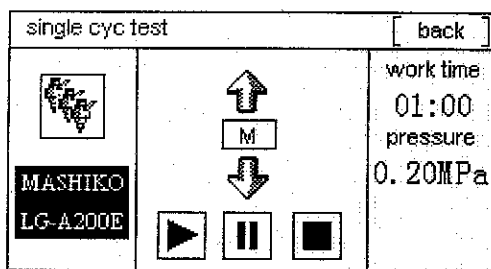

Touch “single cyc” item to enter single cyc test function. Touch “work key” to run the function. During running, you can adjust working pressure by touching up and down arrow.

“pause key” to pause the function and “stop key” to quit. “back key “ to back to the main menu.

8 Leak Check Test (suggest pressure 0.3Mpa)

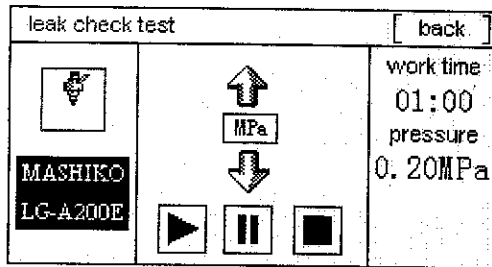

Touch “leak check” item to enter the function. Touch “work key” to run the function. During running, you can adjust working pressure by touching up and down arrow.

“pause key” to pause the function and “stop key” to quit. “back key “ to back to the main menu.

9 No-disassembly Clean

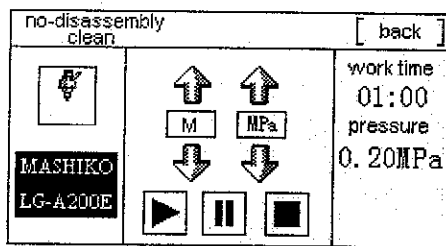

Touch “no-disassembly” item to enter the cleaning function. Touch “work key” to run the function. During running, you can adjust working pressure and time by touching up and down arrow.

“pause key” to pause the function and “stop key” to quit. “back key “ to back to the main menu.

10 Simulate Test

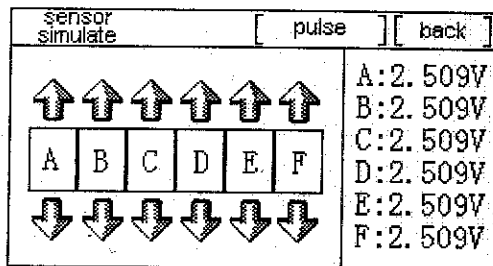

Touch “simulate” item to enter the simulate signal function. You can switch to pulse signal function by touching “pulse signal” item on top right corner to enter pulse signal working interface. Touch “back” to main menu.

11 Pulse Test

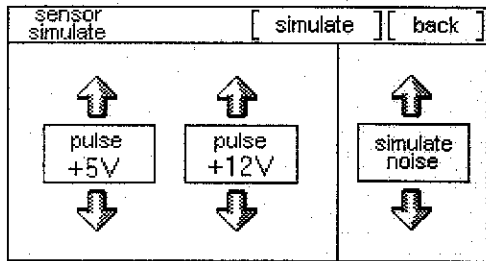

Pulse signal simulating function. You can switch to simulate signal function by touching “simulate signal” item on top right corner to enter simulate signal working interface. Touch “back” to main menu.

Sensor Simulate Function Instruction

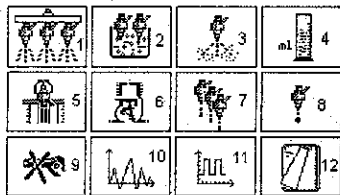

PIC 1

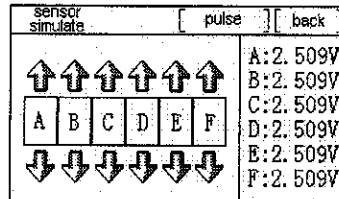

PIC 2

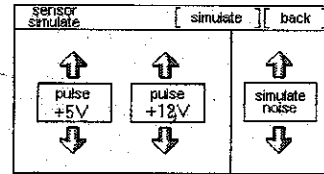

PIC 3

In main interface (pic1), touch “simulate” item to enter this function(pic 2).

Simulate Signal

In simulate signal work interface (pic 2), the A,B,C,D,E,F are controlling simulate signal's output, and respectively for shocking/pressure/liquid level/temperature/oxygen content/flux sensor.

Operation flow:

Take shocking sensor simulate for example. The key 2 with words “explode shock” is the work key; you can run the function by touching it. If you want to stop it just touch it for a second time. Arrows 1 and 3 are for increasing or decreasing export signals, and the range is 0-5V. Touch key 4, it will switch to pulse signal work interface. Key 5 to back to main menu. The current export signals are shown on the right.

Pulse Signal

In pulse signal simulate work interface (pic 3), here we offered 5V pulse signal simulate and 12V pulse signal simulate and explode shock noise simulate.

Operation flow:

Take 5V pulse signal for example. The key 2 with words "pulse signal 5V" is the work key; you can run the function by touching it. If you want to stop it just touch it for a second time. Arrows 1 and 3 are for increasing or decreasing export signals. Touch key 4, it will switch to simulate signal work interface. Key 5 to back to main menu.

Key 6 is work key for explode shock noise producer. Touch to start, touch again to stop. During working, the noise signal will be given out by explode shock simulate end (A)

Preparation and Checking Standard

Preparation

1. No naked fire or smoking around the unit.
2. Connect the unit with AC110V, 50/60Hz power supply.

Turn on the switch to run the unit.

3. Injecting Testing Liquid.

Pour two bottles of the special testing liquid (about 1800ml) into circular holes above measuring cylinder.

After leaving the liquid unused for long time, change new ones for using again!

4. Injecting Cleaning liquid

step 1: Install the cleaning bracket in the ultrasonic cleaning trough.

step 2: Pour the special cleaning liquid into the trough to soak the bracket surface.

Note: Damage will occur if running the machine without cleaning liquid in trough!

5. Prepare the Injectors

step 1: Remove injectors from vehicles.

step 2: Take off the dustproof rubber mat and "O" ring on the bottom.

step 3: Check if the O ring was damaged, if it was, change for a new one.

step 4: Cleaning the external of the injector with petrol or some cleaning liquid to remove the impurity and smear, then rub-up.

step 5: Blow-Drying the injector with purified compressed air.

Install Injector to Unit

1. Install the top-filled Injector (Illustration 2.1)

1.1 Install the injector to a balance position on the fuel distributor with incidental multiple bonder.

1.2 Block the exit without injector with plug.

- 1.3 Lay some lube on the “O” ring and compound bonder.
- 1.4 Rotate the injector lightly and press it into the compound bonder.
- 1.5 Put the fuel distributor and injectors flatly on the panel-16, then fasten by the lock-poles-2.
- 1.6 Connect fuel distributor to fuel tube of the machine by fast-connector.
- 1.7 Select the idling speed test function; turn the knob left to make the pressure in the lowest level.
- 1.8 Press to start the function.
- 1.9 Turn the knob right slowly to increase the pressure to 0.25Mpa and check if there was a leaking on connecting point of bonder.

If a leaking was found, regulate again till wholly sealed.

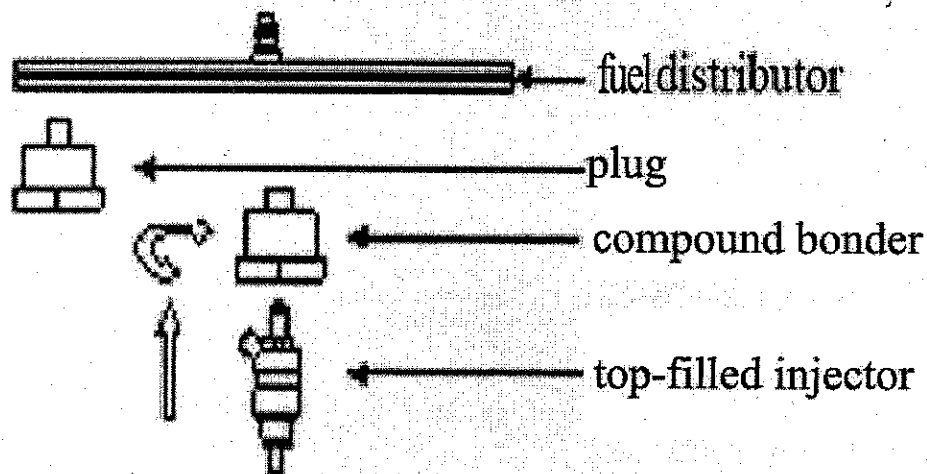

Illustration 2.1 Scheme of Installation of top-filled injector Bonder

2. Install the Side-filled Injector (Illustration 2.2/2.3)

- 2.1 Install the extension bar (13) on the two sides of measuring cylinders bracket.
- 2.2 Screw the pole-5 into the relative holes on the fuel distributor, regulate them with nut to a proper position.
- 2.3 Measure the length “h” of “o” shape coils and depth “H” of bonders.
- 2.4 $H-h = a$, Then a is the thickness of rubber pad under injector, the

thickness can be made with pads A1/A2/A3/A5 and B1/B2/B3/B5. A1 and B1 thickness for 1mm, A2 and B2 thickness for 2mm, A3 and B3 thickness for 3mm, A5 and B5 thickness for 5mm.

2.5 Choose the relative cone-shaped rubber coil-9, and Install it on the injector, then put the pads into the bonder.

2.6 Put the injectors with cone-shaped rubber coil into the bonders.

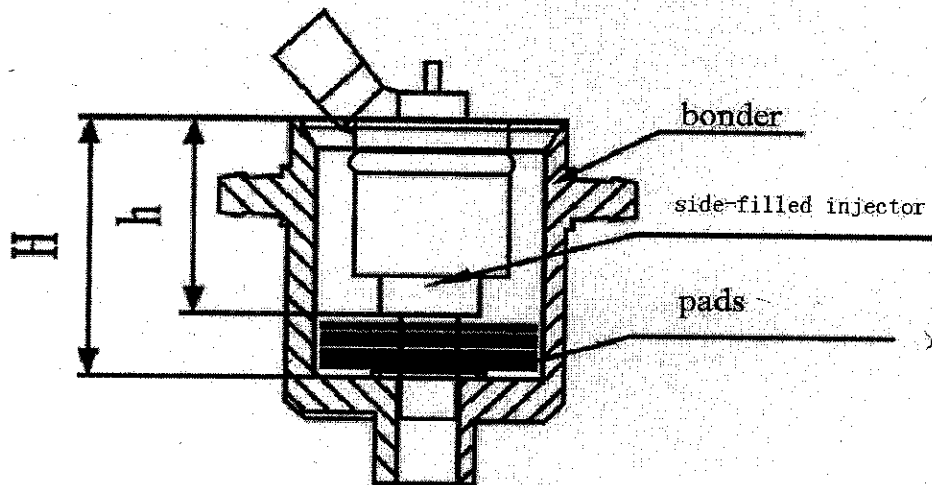
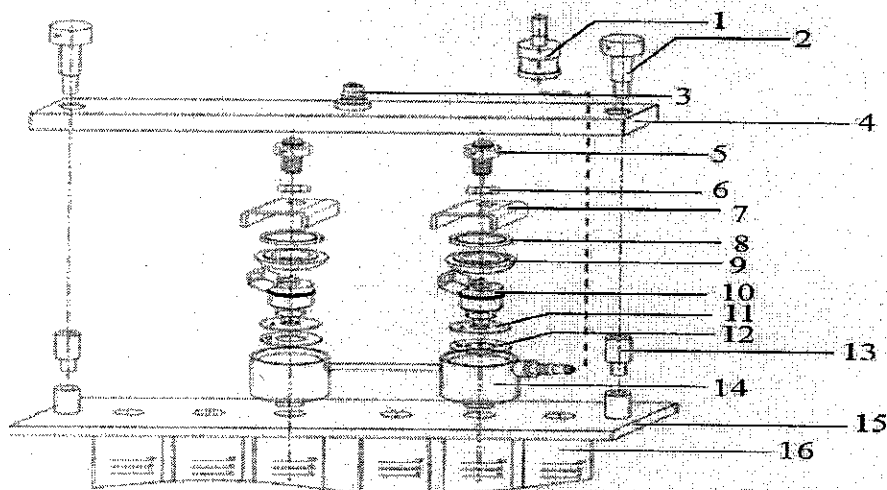

Illustration 2.2 Scheme of Installation of Side-filled Injector Bonder



- | | |
|-------------------------------|---------------------------|
| 1. inserting connector | 9. subulate pad A/B/C/D/E |
| 2. lock-pole | 10. side-filled injector |
| 3. fuel distributor connector | 11. pad A 1,2,3,5mm |
| 4. fuel distributor | 12. pad B 1,2,3,5mm |
| 5. screw | 13. extension bar |
| 6. nut | 14. bonder Base |
| 7. "U" board | 15. inserting plate |
| 8. steel coil | 16. measuring cylinder |

Illustration 2.3 Scheme of Installation of Side-filled Injector

3. Installing Injector for Reverse Flushing (Illustration 2.4)

3.1 Install the extension bar (8) on the two sides of measuring cylinders bracket.

3.2 Screw the reverse flushing bonder (5) on the fuel distributor.

3.3 Put the reverse flushing bonder (9) on the cylinder bracket.

3.4 Put $\Phi 22 \times 3.1$ "O" shape loop on the output of injector.

3.5 Regulate and Install it on reverse flushing bonders (5/9).

3.6 Fasten the lock-pole (2).

3.7 Install the high pressure tube connector.

3.8 Insert the drive line plugs into injectors.

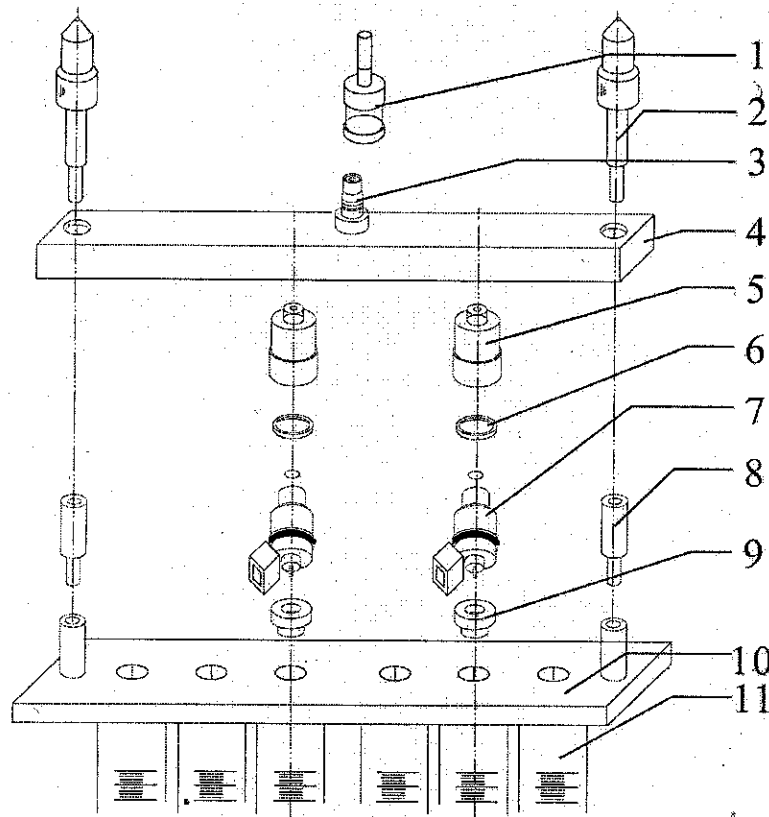

1 inserting connector

2 lock-pole

3 fuel distributor connector

4 fuel distributor

5 up-bonder

6 sealing coil $\Phi 24$

7 top-filled injector

8 extension bar

9 down-bonder

10 inserting plate

11 measuring cylinder

Illustration 2.4 Scheme of Installation of Reverse Flushing Bonder

Checking

1. Flow Proportionality

- 1.1 Regulate the system pressure to fit the injectors.
- 1.2 Test the flow proportionality in different engine speed.
- 1.3 Pause or stop the function and observe the distributive volume when cleaning liquid's amount is less than 2/3 of cylinder capacity.
- 1.4 The discrepancy among injectors of one vehicle should not surpass 2%.

2. Leak Detecting Test

The function is used to check the leak tightness of injector's needle valve in high pressure.

- 2.1 Select this function, press the  key to start.
- 2.2 Regulate the system pressure to 0.3Mpa.

Diagnose: No leaking should be found in one minute.

3. Observe the Spray State

Simulate the working state of all injectors on one vehicle in different engine speed.

- 3.1 Check the spray situation to make sure if they are identical.
- 3.2 Regulate the pulse duration, check if the injectors' minimum pulse duration were identical.

Diagnose: The spray volume, spray angle, atomization, uniformity, the minimum pulse duration should be identical.

Operation Guidelines

Ultrasonic Cleaning

Note: The default cleaning time is 10 minutes; you can reset it before starting.

- 1 Arrange the injectors on the cleaning bracket.
- 2 Connect the drive line plugs with injectors.
- 3 Select the ultrasonic cleaning item, press key to start.

The function will stop automatically as timing out!

- 4 Pick up the injectors and eliminate the Cleaning liquid with soft cloth.

Damage will occur if running the function without adding cleaning liquid in the trough!

Reverse Ultrasonic Cleaning

- 1 Arrange the injectors on the cleaning bracket and keep fuel input port below.

No need driving lines.

- 2 Run the function for one min, the filter could be cleaned.
- 3 Pick up the injectors and eliminate the Cleaning liquid with soft cloth.

Reverse Flushing

- 1 Following the Illustration 2.4, Install the injectors between fuel distributor and cylinders bracket.
- 2 Fasten with lock-pole (2), select the reverse flushing item, regulate the system pressure to 0.25-0.3Mpa, and start the function.

The function will stop automatically as timing out!

- 3 Pick up the injectors and remove the "O" ring.

Flow Proportionality Test & Leak Hunting Test

1 Preparation

- 1.1 Following illustrations 2.1 and 2.3, fasten the injectors between fuel distributors and cylinders bracket.
- 1.2 Tighten the lock-pole.
- 1.3 Keep the system pressure between 0.25-0.3Mpa.

- 1.4 Make sure that there is no leaking.
- 1.5 Select the idling injecting item.

2 Flow Proportionality Test

- 2.1 Turn off the fuel releasing handle valve.
- 2.2 Press ▼▲ (9) to select the items of idling test/medium speed test/high speed test/accelerating test/shifting test.
- 2.3 Press ► to run these functions.
- 2.4 Pause or stop it when liquid level reaches 2/3 of cylinder.
- 2.5 Checking the flow Proportionality in different working states.
- 2.6 Pick out the unqualified ones to clean again.

If it was still unqualified after many times' cleaning, exchange for a new injector!

- 2.7 At last turn on the fuel releasing handle valve to release the liquid back to tank.

3 Leak Detecting Test

- 3.1 Install the injectors.
- 3.2 Press ▼▲ to select the leak detecting item.
- 3.3 Regulate pressure to 0.3Mpa.
- 3.4 Press ► to start.
- 3.5 Checking injectors' leak tightness.
- 3.6 Pick out the unqualified ones to clean again.

If it was still unqualified after many times' cleaning, exchange for a new injector!

Setting for Injecting Times

- 1 Press ▼▲ (9) to select the idling/medium/high speed injecting times setting items.
- 2 Press ▼▲ (6) to set the times.
- 3 Press ► to start.

Keep observing the spray shape and amount as running.

The function will stop automatically as timing out.

Tidy and Maintenance

Tidy

step 1: Shut down the power supply.

step 2: Put the liquid back to the original bottle, clean the machine with dry soft cloth.

step 3: The testing liquid in tank should be put back to original bottles for preservation.

Maintenance

Exchange Cleaning liquid

After being used for long time, the liquid must be changed to avoid that the injector being blocked by the impurity.

Exchanging Process

step 1: Remove off the fuel-release screw cap to let all the liquid out.

step 2: Pour some new liquid in to wash the inside and release.

step 3: Install the screw cap on, add two bottles of new Cleaning liquid.

Exchange Protector Tube

step 1: The protector case is on the unit's power receptacle.

step 2: Open the case, you will see the tube.

step 3: Change for a new one if the tube was melted.

Notice

1. The measuring cylinders are made of quartz glass, and fragile. **Please avoid striking!**
2. Before start the unit, please check the power supply, connector plugs and protector tube to ensure that they are in good condition.
3. Warranty will cancel if dismantle the unit without permission.
4. Damage will occur if running the ultrasonic cleaning function without special Cleaning liquid.
5. Before exchanging for new testing liquid, the used ones must be released entirely, then adding two bottles (1800ml) for using.
6. Taking use of the special testing or Cleaning liquids which designed for unit, for other ones will flake the surface painting coat off.
7. Never using coal fuel, petrol or thinner for as cleaning or testing liquid.
8. Never mix the testing and Cleaning liquids for usage.
9. The trouble caused by using other liquid or liquid is beyond the repairing guarantee range.

The Cleaning and Testing Liquid

Safety and Innocuity, the liquid are specially designed for the unit and composed of sediment controlling liquid, with high stability and oxidation resistance, resuming injector unimpeded, normal spray, eliminate the troubles of idling unsteadiness, accelerating hard, and improve combustion performance, saving the petrol cost.

To avoid burning the unit core fuel pump and fretting the fuel piping system, the liquid are kept from any acid or base component. from any acid or base component.

Accessories

No.: A60001
Name:
Instruction
Amount: 1

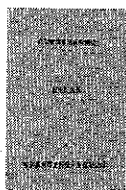

No.: A60002
Name: Driving
Lines
Amount: 1



No.: A60003
Name: Fuel
distributor
Amount: 1



No.: A60004
Name:
Driving Line
Amount: 1



No.: A60005
Name: Top-filled
Bonder
Amount: 4/6/8



No.: A60006
Name: Fuel distributor
Sealer
Amount: 3/5/7



No.: A60007
Name: Side-filled
Bonder Base
Amount: 1



No.: A60008
Name: Side-filled
Subulate
Pad; A/B/C/D/E
Amount: 10 of 5 kinds



No.: A60009
Name: Side-filled Pad
A1, A2 A3, A5
Amount: 8 of 4 kinds



No.: A600010
Name: Side-filled
Pad B1, B2, B3, B5
Amount: 8 of 4 kinds



No.: A600011
Name: Side-filled "U"
board
Amount: 2



No.: A600012
Name: Side-filled
Screw
and Nut



No.: A600013
Name: Side-filled
Steel Coil
Amount: 2



No.: A600014
Name: Reverse-Flush
h Bonder
Amount: 4/6/8



No.: A600015
Name: Reverse-Flush
Bonder
Amount: 4/6/8



No.: A600016
Name: Reverse-Flush
Sealing coil
Amount: 4/6/8



No.: A600017
Name: Ultrasonic
Cleaning Bracket
Amount: 1

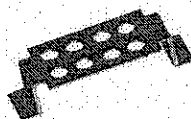

No.: A600018
Name: Lock-pole
Amount: 2

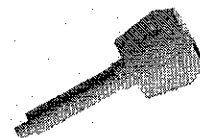

No.: A600019
Name: Extension
Bar
Amount: 2



No.: A600020
Name: Pad for
microbus injectors
Amount: 1

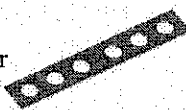

No.: A600021
Name: Diverting
Line
Amount: 4/6/8



No.: A600022
Name: Extension
Pad for Microbus
Injector
Amount: 2



No.: A600023
Name: Protector
Tube
Amount: 2

